

MODIFIED DEADBEAT PREDICTIVE CURRENT CONTROL METHOD FOR SINGLE-PHASE AC–DC PFC CONVERTER IN EV CHARGING SYSTEM

¹ Dr. Surendhar Reddy, ² Dr. Abdul Rahuman Mohammad Ishak, ³ CH Swathi, ⁴ S Roda Vishal, ⁵ R Swathi

^{1,2} Professor ^{3,4,5} Asst Professor, Department of EEE, Balaji Institute of Technology & Science, Warangal-Narsampet Rd, Laknepally, Madhira D, Telangana 506330

Abstract—

Nowadays, use of conventional vehicles is increasing rapidly, which cause to rise pollution and dangerous environmental effects. Hence, Electric vehicle comes into a picture, because they run on no or very less fuel. This vehicle totally runs on battery, so battery charger system should be fast and work effectively. So, here in our paper we have used boost converter to charge our battery. Along with this we have also used rectifier circuit, CT, PT, micro-controller. We used boost converter because it is a chip and boost output voltage that's why efficiency of battery charger increases. Here, we try to maintain power factor at AC side near to unity that's why losses in system decrease and ultimately efficiency increases. Simulation in the paper shows the practical output of our topic, which is nearly unity and output waveform is almost ripple free. So, we get almost DC wave for battery charging.

Keywords— Electric vehicles (EV), Proportional Integral Derivative (PID), Metal Oxide Semiconductor Field Effect Transistor (MOSFET), Boost converter, Comparator, Power Factor Correction (PFC).

INTRODUCTION

Emerging trends in vehicles nowadays have created huge progress in a field of automobiles, but rapid increase in a number of conventional vehicles leads to increase in pollution and also use of fuel. This both factors have very harmful and dangerous effect on economy as well as health too. So to overcome all these challenges there is an invention of Electric Battery vehicle. Electric vehicle includes Electric lorries, electric trains, electric cars, Electric-trucks. Battery is the virtual soul or heart of EV. The design of the battery should be such that it should be able to charge itself fast and work efficiently. EV has zero fuel emission. EV works on very less or no fuel, so it is a green energy. EV runs on battery so the battery needs to be charged daily. Hence we need an efficient as well as fast battery charger. Hence this topic comes into a picture.

Here transformer is used to step down the voltage of 230V to 12V. We have used a rectifier to convert AC-DC as battery needs DC supply. Capacitors are also used here as a filter to remove the distortions in a signal. And due to this EV battery chargers have very high efficiency. Here we have used a Boost converter because it is the cost-effective and most reliable solution for both input current shaping capability and voltage regulation. Boost converter is DC-DC type of converter.

Which is used to step up the voltage at the output side.

BLOCK DIAGRAM AND WORKING

The Block diagram for the proposed work is shown in the below figure (3) this project consists of three main circuits those circuits are:

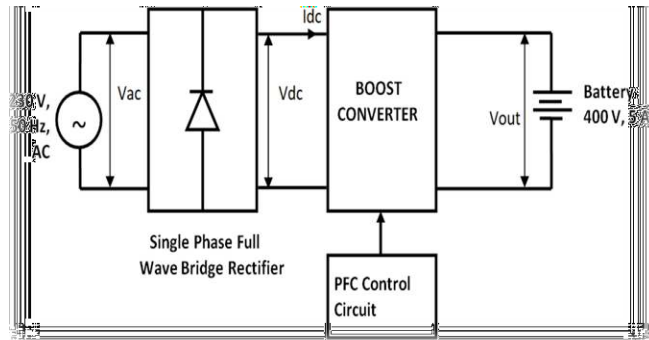

Fig.(1):Block diagram of Power factor Conversion technique for EV Battery Charging

As shown in the Block Diagram the 230 Volt AC Supply is given to the Bridge Rectifier. The Bridge Rectifier is Single-phase Full Wave Bridge Rectifier as it is termed an Uncontrolled rectifier in that the applied input voltage is passed directly to the output terminals providing a fixed average DC 207.06 Volt. The Output of the Rectifier is given to the Boost Converter. The output voltage of the bridge rectifier is connected to the Inductor the rating of the inductor is 0.3mH. The solid-state device which operates as a switch is connected across the bridge rectifier which is MOSFET. The gate pulse of MOSFET is given by the PFC Control Circuit which is used for improving the power factor of the Circuit and to improve the efficiency of the circuit. The diode is connected to a capacitor; the rating of the capacitor is 2000 microfarad which is used to ripple by smoothing capacitors that convert the ripple voltage into a smoother dc voltage. As a Load, the battery is used. The rating of the Battery is 400 Volt and the State of Charge of the battery is kept at 30, so the battery gets charged up to 400 Volt.

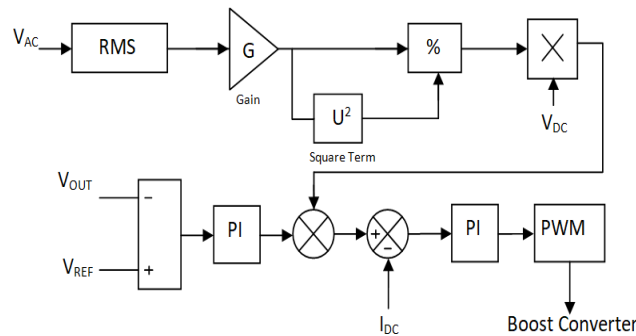

FIG.2: BLOCK DIAGRAM OF PFC CONTROL CIRCUIT

We need to detect peak value of AC input voltage in order to generate sinusoidal reference for the current controller. Then we have voltage regulator to control voltage which is followed by the current controller. It controls inductor current and also maintains sinusoidal wave shape and finally the output is given to the PWM block which is connected to the gate terminal of the MOSFET

Output of Simulation of Input Supply:

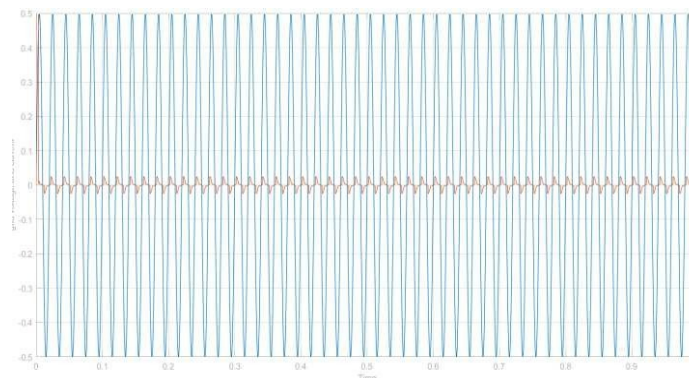

Fig.3: Input AC Supply Voltage and Current

As shown in Fig.3 It is the Simulated Waveform of Input side Voltage and current which is AC Waveform. The RMS value of Voltage is 230 Volts, its peak value is 325.26 Volts and the Current is 0.03 Ampere as the Battery is fully charged.

Output of Simulation of Bridge Rectifier:

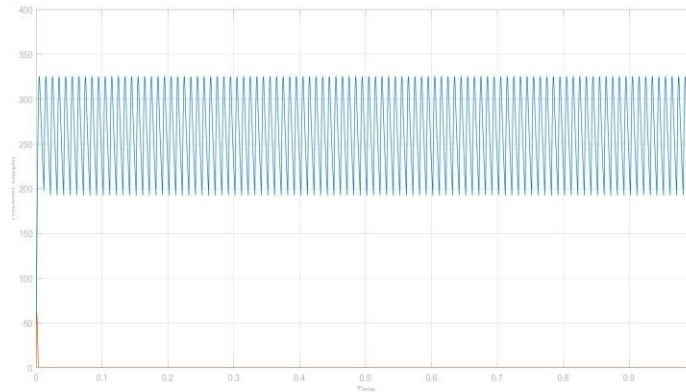

Fig.4: Output Voltage and Current Waveform of Bridge Rectifier

Output Current Waveform of Bridge Rectifier As shown in the Waveform, It is the Simulated Output Waveform of the Bridge Rectifier which is DC Voltage and Dc Current. The average output voltage of the Bridge Rectifier is 207.06 Volts, and the average current is 0.002 ampere.

Output of Simulation of Battery:

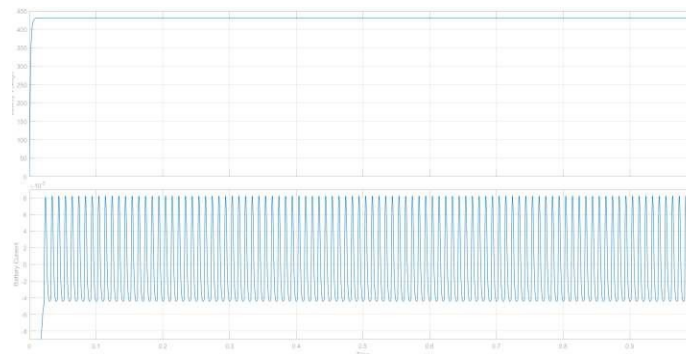

Fig.5: Output Waveform of EV Battery

As shown in the Waveform, It is the simulated output Waveform of Charging of the Battery, The Battery gets Charged up to 430 Volt as the State of Charge of the Battery is 50% and the current is up to 0.008 Ampere.

Power factor Improvement of Battery:

When the angle between Current and Voltage comes near to the unity then It is called an improved power factor, In the tapping of the Boost Converter, the gate pulse is taken from the closed-loop as the Feedback is taken from the Output. In the Feedback circuit, the logic is designed in such a way that the switching operation of MOSFET is done at Zero crossing means current and Voltage is remaining in phase and then the power factor get improved in Battery as the Load is Battery.

Calculation of parameters:=

INPUT SUPPLY VOLTAGE

$$\text{Input Voltage (RMS)} = 230 \text{ Volts}$$

$$V_{\text{max}} = V_{\text{RMS}} * \sqrt{2}$$

$$= 325.26 \text{ Volts}$$

Rectifier Calculation:

$$V_{dc} = 2V_m / \pi$$

$$= 2 * 325.26 / \pi$$

$$= 207.06 \text{ Volts}$$

Calculation Of DC-DC Converter

Lithium-ion-Battery (V_{out}) = 400 Volts V_{dc} (V_{in}) = 207.06 Volts Duty

$$\text{Cycle Ratio (D)} = 1 - V_{in} / V_{out}$$

$$= 1 - 207.06 / 400$$

$$= 0.5$$

Capacitor = 2000 μ F

Inductor = 0.3 mH

Advantages of Power Factor Correction Device:

- 1) Improves Power Factor.
- 2) Improves efficiency.
- 3) Battery get charged at rated voltage.

CONCLUSION:

As we assume that our battery voltage must reach upto 400 volts, but when we performed our simulation we observe that the maximum reach of battery is 430 volts. As we give the Input Supply as 230 Volts AC, It get converted into DC by using Bridge Rectifier and the average value of Rectifier is 207.06 Volt DC so it get Step upto 400 Volts by using Boost Converter, so we got the results as per our expectations.

The expected outcome of this paper is to improve the power factor of the Electric Vehicle Battery by using the Zero Crossing Detection technique as the Feedback is taken from the output in a closed loop and switching the MOSFET at zero crossing thus the angle between the current and voltage waveform reduces and power factor comes near to unity and the voltage is also boosted by using boost converter, The ripple is reduced by using the smoothing capacitor which transforms the ripple voltage into smoothing DC voltage. Thus overall efficiency of the Battery is improved and the performance of the battery also gets improved

REFERENCES:

- [1] V. Bharath Kumar and M. R. Sindhu, "EV Charger Power quality Improvement using Synchronous rectified Bridgeless CUK Converter," 2021 IEEE International Power and Renewable Energy Conference (IPRECON), 2021, pp. 1-6, doi:10.1109/IPRECON52453.2021.9641057
- [2] S. Kim and F.-S. Kang, "Multifunctional Onboard Battery Charger for Plug-in Electric Vehicles," in IEEE Transactions on Industrial Electronics, vol. 62, no. 6, pp. 3460-3472, June 2015, doi: 10.1109/TIE.2014.2376878.
- [3] N. Liu, Q. Chen, X. Lu, J. Liu and J. Zhang, "A charging strategy for pv-based battery switch stations considering service availability and self-consumption of pv energy", *IEEE Transactions on Industrial Electronics*, vol. 62, no. 8, pp. 4878-4889, 2015.
- [4] Z. Bi, L. Song, R. De Kleine, C. C. Mi and G. A. Keoleian, "Plug-in vs. wireless charging: Life cycle energy and greenhouse gas emissions for anel
- [5] Y. J. Jang, G. H. Choi and S. I. Kim, "Modeling and analysis of stockers system in semiconductor and LCD fab", *Proc. IEEE Int. Symp. Semicond. Manuf. (ISSM)*, pp. 273-276, Sep. 2005.
- [6] J. Shin et al., "Design and implementation of shaped magnetic-resonance-based wireless power transfer system for roadway-powered moving electric vehicles", *IEEE Trans. Ind. Electron.*, vol. 61, no. 3, pp. 1179-1192, Apr. 2014